



TP-201Y

- Painted steel frame
- Ideal for dirty strapping environment, such as sawmill plants, brick and tile industries
- Adjustable table height between 420 mm and 770 mm

Option

- ▶ New generation machine TP-501Y with auto strap loading

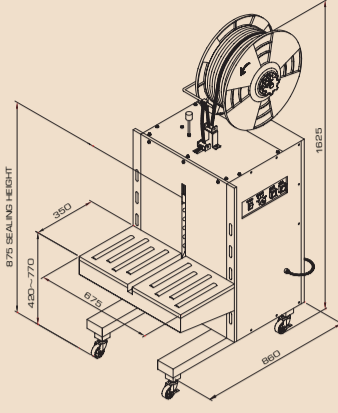

TP-201YS

- Stainless steel frame SUS 304 and selected parts in stainless steel
- Ideal for moist strapping environment, such as meat, fish, poultry and agricultural processing plants
- Adjustable table height between 420 mm and 770 mm

Option

- ▶ New generation machine TP-501YS with auto strap loading



TP-201YM

- Stainless steel frame SUS 304 and rust resistant and corrosion retardant parts.
- Ideal for moist and harsh packaging environments, such as marine food, meat, and poultry industries.
- Waterproof design to protect the machine from water and wash down spray
- Special protection for the electric control unit to ensure highest safety
- Adjustable table height between 410 mm and 760 mm

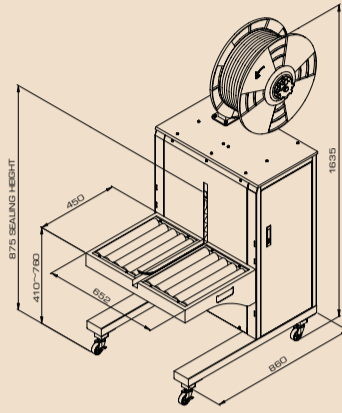

Main Features:

- ▶ Semi-auto side-seal strapping machine offers reliability and high performance
- ▶ Suitable for low volume applications
- ▶ Low maintenance is required
- ▶ Mechanical tension control

TECHNICAL DATA

Strap Width: 6 mm-15.5 mm adjustable
 Strap Tension: 15 kg to 45 kg
 Net Weight: TP-201Y/TP-201YS: 125 kg
 TP-201YM: 126 kg
 Power: 110V, 220V, 230V 50/60Hz 1PH

All specifications subject to change without notice.



Idépack Verpakingsmachines B.V.
 Zeilmaker 8
 NL-3861 SM NIJKERK
 The Netherlands

Tel: +31(0)33-299 00 08
 Fax: +31(0)33-299 66 67
 info@idepack.com
 www.idepack.com

04.2006x2000

SIDE-SEAL

STRAPPING MACHINE

The sealing head is mounted on the side of the machine frame to protect it from dust and water. These machines can be used in a dirty, moist or harsh strapping environment, such as marine food, meat, poultry processing, sawmill or brick plants. In this category, we have three product lines:

- Semi-Auto machine
- Automatic machine
- Fully-Auto machine



Automatic Machine

Tauris



TP-601Y

- Painted steel frame
- Ideal for dirty strapping environment, such as sawmill plants, brick and tile industries

Option

- ▶ Without adjustable roller table (TP-601Y-XT)



TP-601YS

- Stainless steel frame SUS 304 and selected parts in stainless steel
- Ideal for moist strapping environment, such as meat, fish, poultry and agricultural processing plants

Option

- ▶ Without adjustable roller table (TP-601YS-XT)



TP-601YM

- Stainless steel frame SUS 304 and rust resistant and corrosion retardant parts.
- Ideal for moist and harsh packaging environments, such as marine food, meat, and poultry industries.
- Waterproof design to protect the machine from water and wash down spray
- Special protection for the electric control unit to ensure highest safety

Option

- ▶ Without adjustable roller table (TP-601YM-XT)

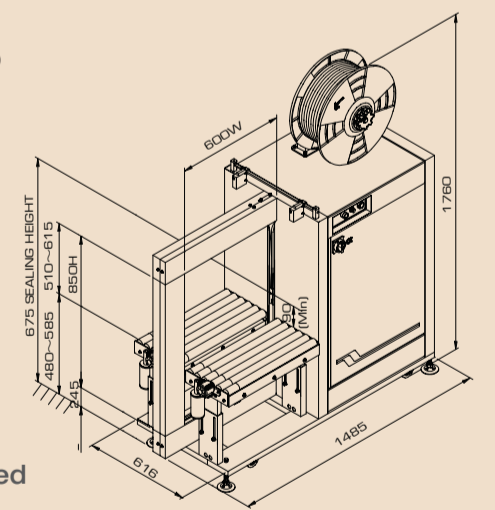
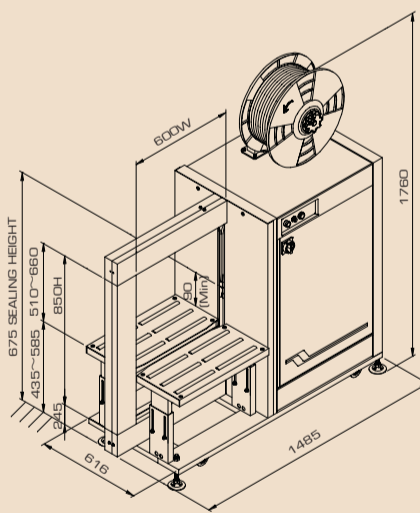

Main Features:

- ▶ Automatic side-seal strapping machine offers reliability and high performance
- ▶ Auto strap feeding
- ▶ Electronic tension control
- ▶ Auto strap ejector
- ▶ Larger arch sizes are available for large packages
- ▶ Easy adjustable roller table height (minimum height: 435 mm)

Arch Sizes:

| H | W | 400 | 600 | 800 | 1000 |
|------|---|-----|-----|-----|------|
| 650 | | | | | |
| 850 | | | Ⓢ | | |
| 1050 | | | | | |
| 1250 | | | | | |

- Standard size: 600 mm(W) x 850 mm(H)
- Maximum package size: 590 mm x 650 mm
- Larger arches are available on request

TECHNICAL DATA

Strap Width: 8 mm-12 mm
 Strap Tension: 7 kg to 70 kg
 Speed: 29 straps/minute (60Hz)
 Net Weight: 300 kg
 Power: 110V, 220V, 230V, 380V, 415V
 50/60Hz 1PH or 3PH

Fully-Auto Machine

Tauris



TP-601YA

- Painted steel frame
- Ideal for dirty strapping environment, such as sawmill plants, brick and tile industries

Options

- ▶ Siemens PLC control
- ▶ Without adjustable roller table (TP-601YA-XT)



TP-601YAS

- Stainless steel frame SUS 304 and selected parts in stainless steel
- Ideal for moist strapping environment, such as meat, fish, poultry and agricultural processing plants

Options

- ▶ Siemens PLC control
- ▶ Without adjustable roller table (TP-601YAS-XT)
- ▶ Exclusively designed for marine food industry TP-601YAM (to be available in the 4th quarter of 2006)

Main Features:

- ▶ Fully-Auto side-seal strapping machine offers reliability and high performance
- ▶ Multiple strap function for single, double, triple strapping or transit mode
- ▶ Variable conveyor speed: 10-40 meters/minute
- ▶ Conveyor minimum height: 480 mm
- ▶ Easy adjustable roller-driven table height
- ▶ Auto strap feeding
- ▶ Electronic tension control
- ▶ Auto strap ejector
- ▶ Larger arch sizes are available for large packages

Please note: TP-601YAS is not a wash down machine

Arch Sizes:

| H | W | 400 | 600 | 800 | 1000 |
|------|---|-----|-----|-----|------|
| 650 | | | | | |
| 850 | | | Ⓢ | | |
| 1050 | | | | | |
| 1250 | | | | | |

- Standard size: 600 mm(W) x 850 mm(H)
- Maximum package size: 590 mm x 650 mm
- Larger arches are available on request

TECHNICAL DATA

Strap Width: 8 mm-12 mm
 Strap Tension: 7 kg to 70 kg
 Speed: 29 straps/minute (60Hz)
 Net Weight: 330 kg
 Power: 220V, 380V, 400V, 415V
 50/60Hz 3PH